

CURRENT 3.0 Ampere
 VOLTAGE RANG 50 to 1000 Volts

S3ABF THRU S3MBF

FEATURES

- Plastic package has underwrites laboratory flammability Classification 94V-0
- For surface mounted applications
- Low profile package
- Built-in strain relief, ideal for automated placement
- Glass Passivated chip junction
- High temperature soldering:
250 /10 second at terminals

SMBF

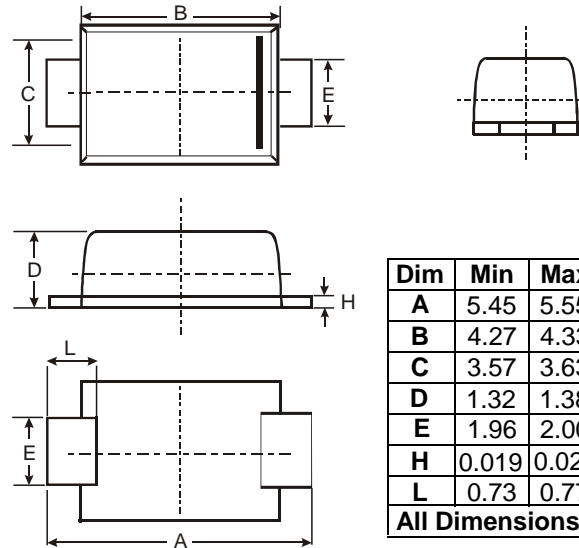

Dim	Min	Max	Typ
A	5.45	5.55	5.50
B	4.27	4.33	4.30
C	3.57	3.63	3.60
D	1.32	1.38	1.35
E	1.96	2.00	1.98
H	0.019	0.021	0.20
L	0.73	0.77	0.75
All Dimensions in mm			

MECHANICAL DATA

Case: JEDED SMBF molded plastic over glass passivated chip
 Terminals: Solder plated, Solderable per MIL-STD-750, method 2026
 Polarity: Color band denotes cathode end
 Weight: 0.003ounce, 0.090 gram

MAXIMUM RATINGS AND ELECTRICAL CHARACTERISTICS

Ratings at 25 ambient temperature unless otherwise specified

	SYMBOLS	S3A	S3B	S3D	S3G	S3J	S3K	S3M	UNIT
Maximum Repetitive Peak Reverse Voltage	V_{RRM}	50	100	200	400	600	800	1000	Volts
Maximum RMS Voltage	V_{RMS}	35	70	140	280	420	560	700	Volts
Maximum DC Blocking Voltage	V_{DC}	50	100	200	400	600	800	1000	Volts
Maximum Average Forward Rectified Current at $T_L=100$ (NOTE 3)	$I_{(AV)}$	3.0							Amps
Peak Forward Surge Current 8.3ms single half sine wave superimposed on rated load (JEDEC method) $T_L=100$	I_{FSM}	100							Amps
Maximum Instantaneous Forward Voltage at 3.0A	V_F	1.15							Volts
Maximum DC Reverse Current at rated DC Blocking Voltage	$T_A = 25$	10.0							A
	$T_A = 125$	250							
Typical Reverse Recovery Time (NOTE 1)	T_{rr}	2.5							s
Typical junction capacitance (NOTE 2)	C_J	60							pF
Typical Thermal Resistance (NOTE 3)	$R_{\theta JL}$	47							/W
	$R_{\theta JA}$	13							
Operating and Storage Temperature Range	T_J, T_{STG}	-55 to +150							

Notes:

- Reverse recovery test conditions: $I_F=0.5A$, $I_R=1.0A$, $I_{rr}=0.25A$
- Measured at 1.0MHz and applied reverse voltage of 4.0 Volts
- Thermal resistance from Junction to ambient and from junction to lead mounted on P.C.B.with 0.3×0.3" (8.0 × 8.0mm) copper pad areas.

CURRENT 3.0 Ampere
 VOLTAGE RANG 50 to 1000 Volts

S3ABF THRU S3MBF

RATING AND CHARACTERISTIC CURVES S3A Thru S3M

F1G.1-FORWARD CURRENT DERATING CURVE

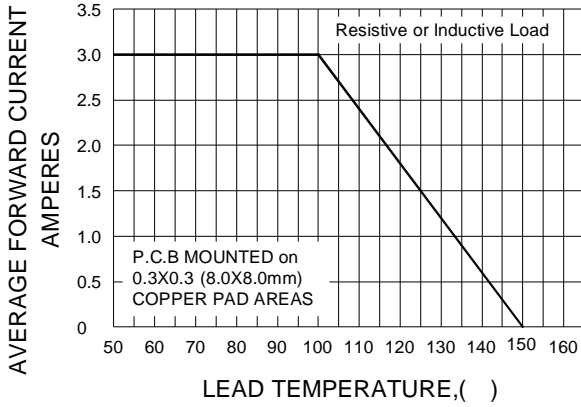

F1G.2-MAXIMUM NON-REPETITIVE PEAK FORWARD SURGE CURRENT

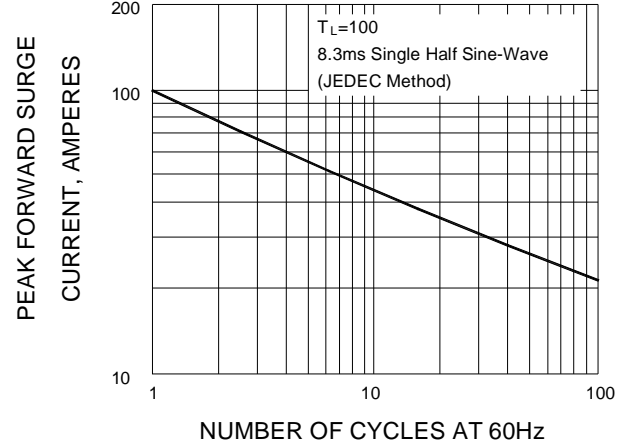

F1G.3-TYPICAL INSTANTANEOUS FORWARD CHARACTERISTICS

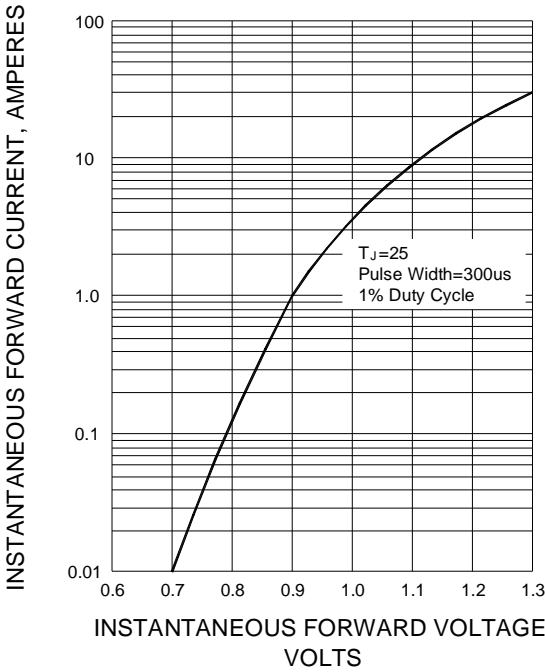

F1G.4-TYPICAL REVERSE CHARACTERISTICS

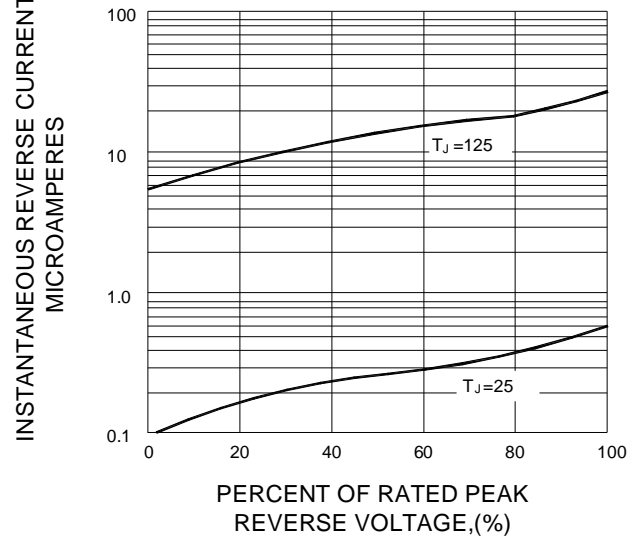

F1G.5-TYPICAL JUNCTION CAPACITANCE

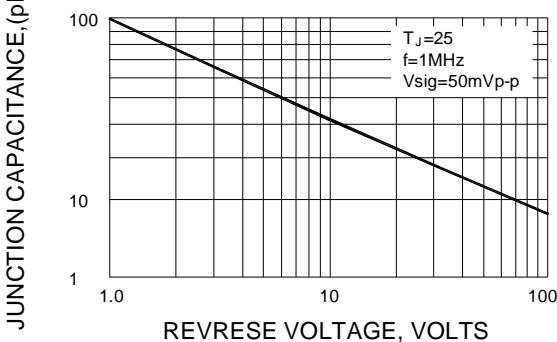

F1G.6-TYPICAL TRANSIENT THERMAL IMPEDANCE

